

1.

INVCP

3.

INVCP

INVCN

KSB ITUR

-
-
-
-
-
-
-
-
-
-
-
-

4.

INVCP 100 / 250 C



2.

		50	60
	з/	1600	1400
		116	102
	°C	100	100
	°C	-10	-10
		10	10
		5410	5410

KSB ITUR.

5.

		00	02	05	12 (1)
	102	JL 1040 (2)	JL 1040 (2)	CF8M (3)	JL 1040 (2)
	161	JL 1040 (2)	JL 1040 (2)	CF8M (3)	JL 1040 (2)
(n)	211, 212	F-114 (4)	F-114 (4)	AISI-316L (5)	F-114 (4)
	230	JL 1040 (2)	CF8M (3)	CF8M (3)	CA6NM (6)
	341	JL 1040 (2)	JL 1040 (2)	JL 1040 (2)	JL 1040 (2)
	502	JL 1040 (2)	JL 1040 (2)	AISI-316L (5)(7)	AISI-316L (5)(7)
	520	AISI-431B (8)	AISI-431B (8)	AISI-316L (5)	AISI-431B (8)
	545	TFM (9)	TFM (9)	TFM (9)	TFM (9)
	711	St 37.0	St 37.0	AISI-316L (5)	St 37.0
	712	St 37.0	St 37.0	AISI-316L (5)	St 37.0
	890	F-111 (10)	F-111 (10)	F-111 (10) (11)	F-111 (10)

- (1) (7) O CF8M
- (2) EN 1561 = GJL-250 (8) 1.4057
- (3) - - 1.4408 (9)
- (4) = C45 (10) = C15
- (5) - - (11)
- 1.4435
- (6) , 1.4313

6.

6.1

6.5

6.2

IEC IM V1.

6.3

TFM ()

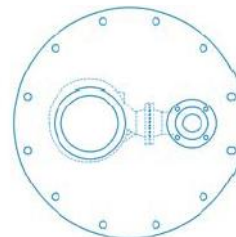

6.4

7.

ATEX
ISO-9001

ATEX (94/9/EC).

8.

"C"

1500 /

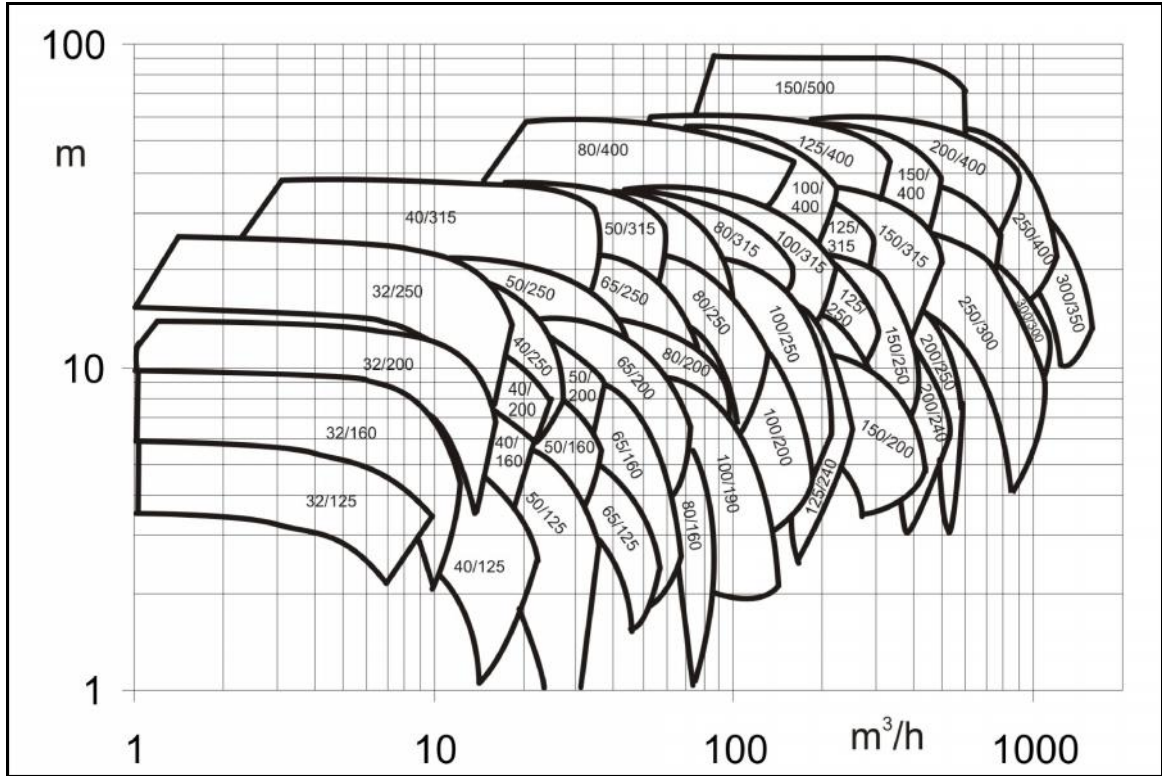

3000 /

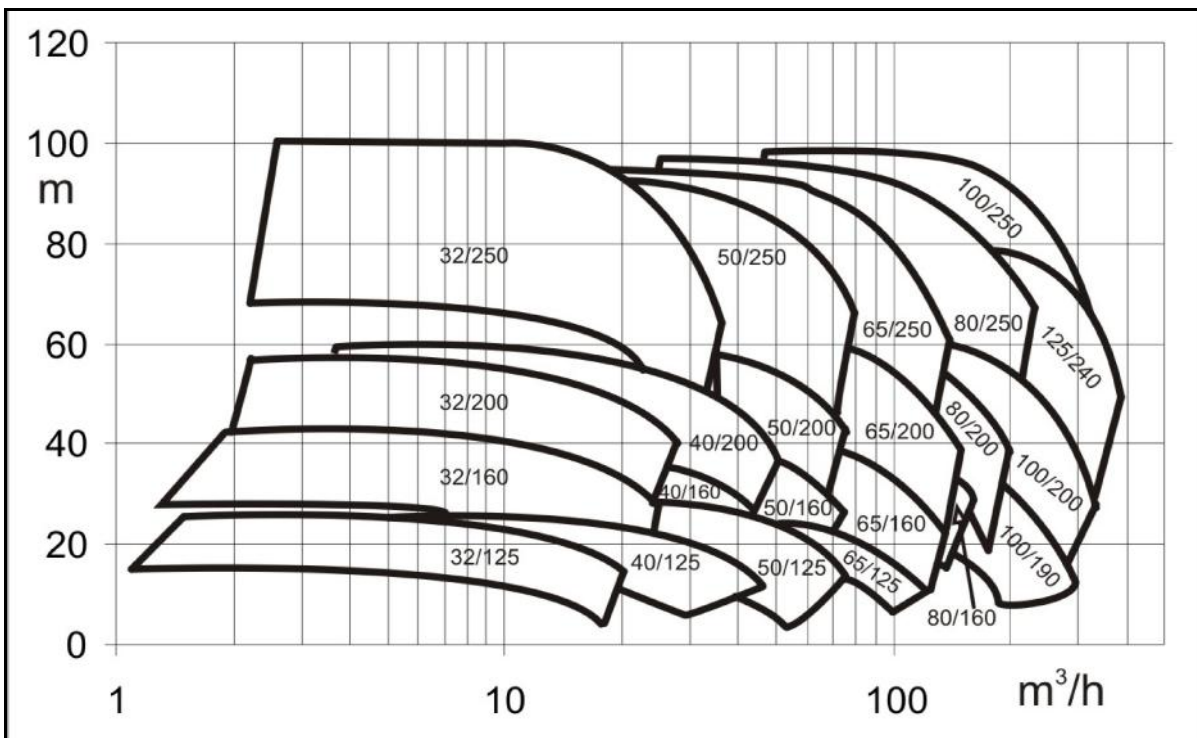

“A”

1500 /

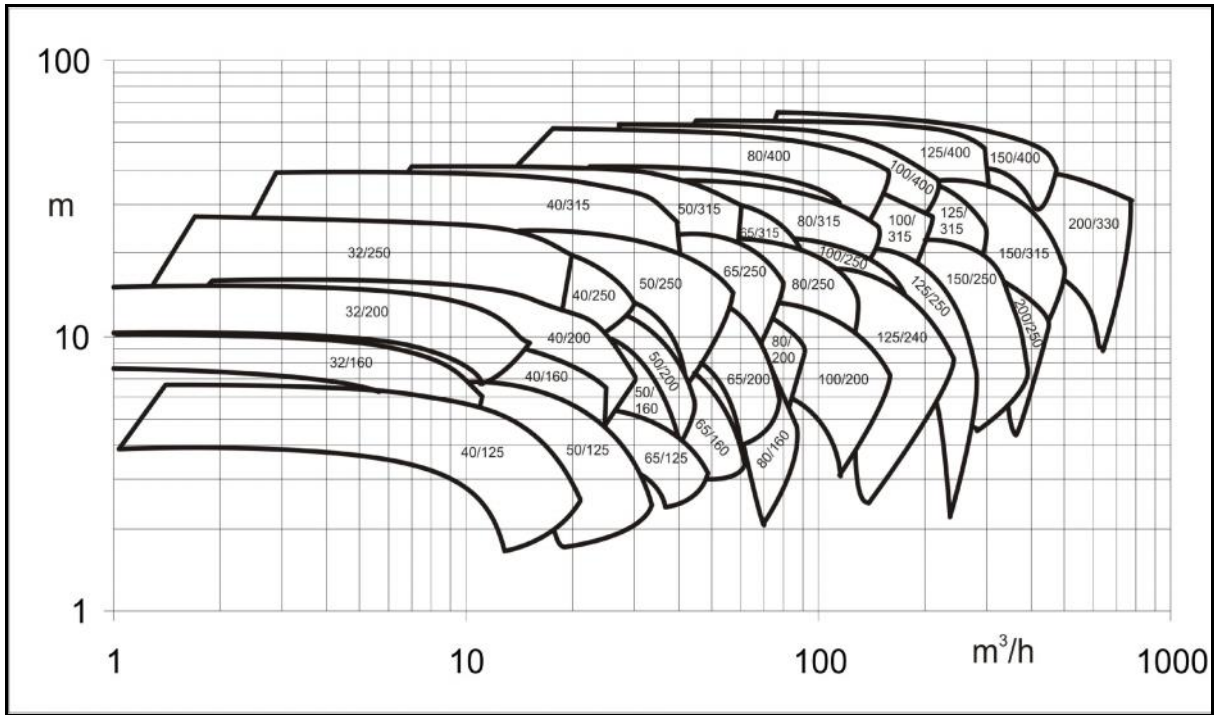

3000 /

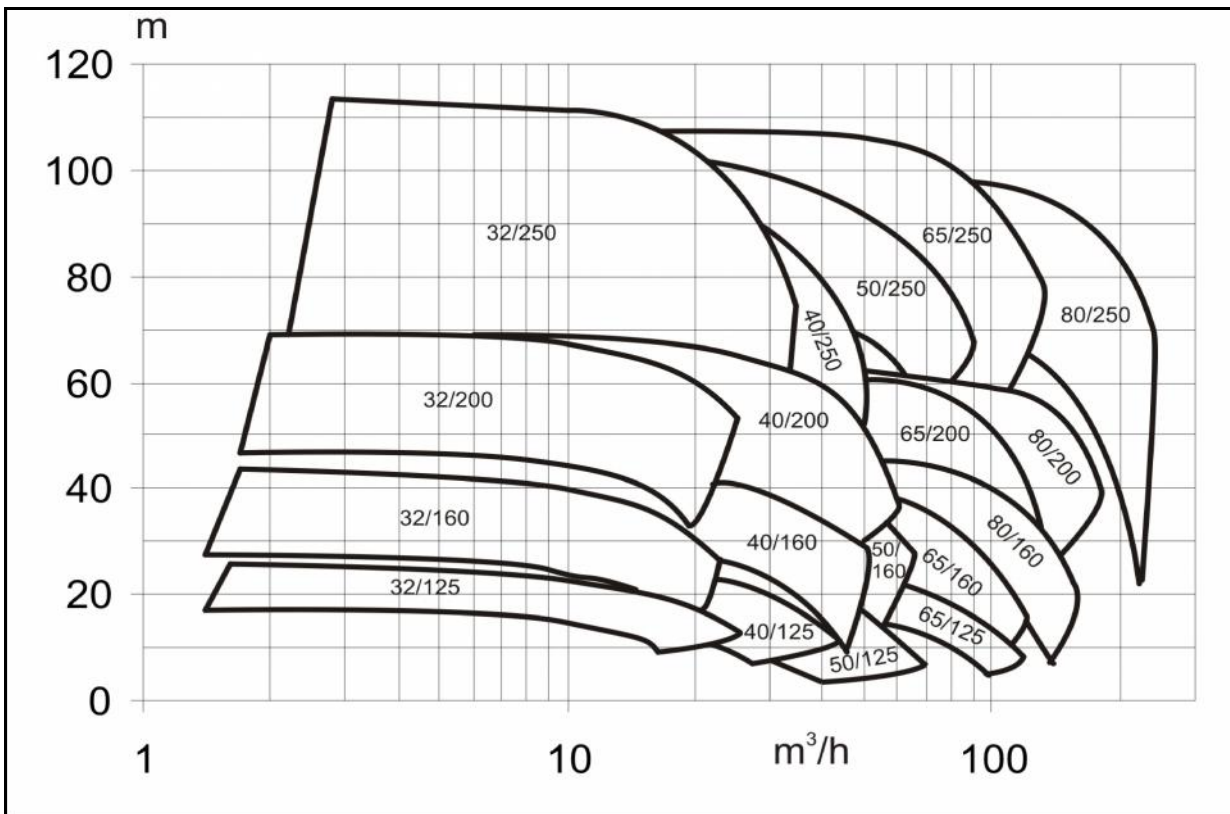

9.

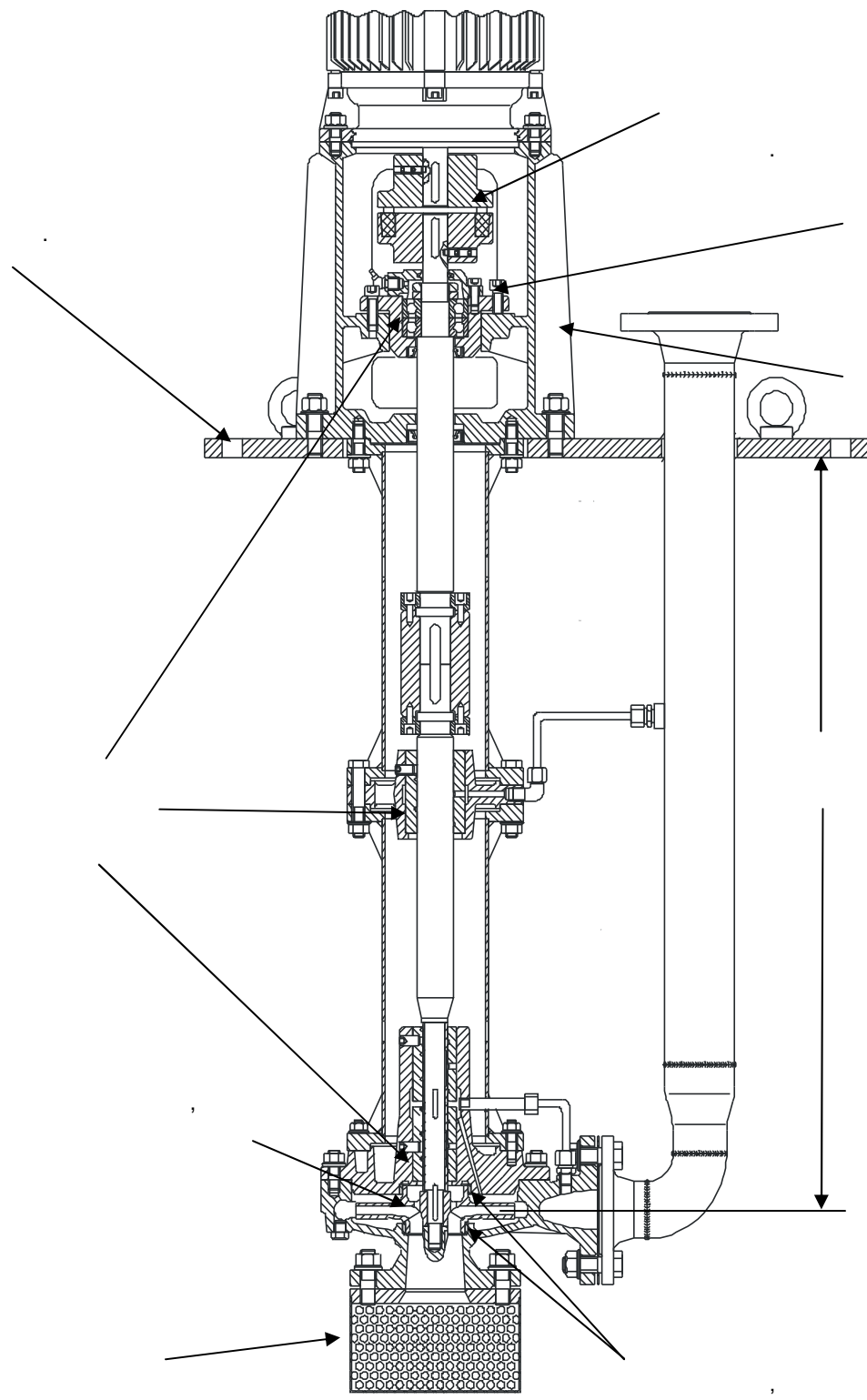

10.

		"C"																																		
		32/125C	32/160C	32/200C	40/125C	40/160C	40/200C	50/125C	50/160C	32/250C	40/250C	50/200C	50/250C	65/125C	65/160C	65/200C	80/160C	40/315C	50/315C	65/250C	65/315C	80/200C	80/250C	80/315C												
		5	4	9	6	5	16	10	5	4	7	5	22	16	12	25	7	7,5	8	7	18	14	9													
	cm ²	10		18			38	28	17	35	36		64		94	38,6	62	36	95	88																
		3			10			3			20	10	20	3	7																					
		16						22						32																						
		35												32																						
	()	2 x 7307												2 x 7310																						
	()	1 x 28/03	2 x 28/03	1 x 28/03	2 x 28/03	1 x 28/03	2 x 28/03				1 x 28/03	2 x 28/03	2 x 40/02																							
	(1)	40/02																																		
	()	« »																																		
	P/n	0,005												0,0137						0,0433																
	()	250												320																						
	1	EN 12756 (DIN 24960)																																		
	Ø (2)	50																																		
	2	Ø8 x 1000																																		

(1) = 10 x (- 1). « »

(2) 10 .

		"C"																																					
		100/190C	100/200C	100/250C	100/315C	125/240C	125/250C	150/200C	150/240C	150/250C	200/240C	200/250C	80/400C	100/400C	125/315C	125/400C	150/315C	150/400C	200/300C	250/300C	150/500C	200/400C	250/400C	300/300C	300/350C														
		29	28	20	17	28	55	40	65	9	11	23	17	33	27	50	77	22	41	58	88	90																	
	cm ²	140	142	95	149	136	142	198	337	76	101	127	158	197	224	463	503	285	439	589	610	774																	
		20	7	20				7	20	7	20																												
		32						42						52																									
		35						50						70																									
		32						48						55																									
	()	2 x 7310												(3)						6314 + 2 x 7314																			
	()	2 x 40/02						2 x 55/01	2 x 55/02	2 x 55/01	2 x 55/02	4 x 650/1	2 x 65/02	4 x 65/02																									
	(1)	40/02						2 x 55/01						2 x 65/01																									
	()	« »																																					
	P/n	0,0433												0,1067						0,2065																			
	()	320												500												650													
	1	EN 12756 (DIN 249560)																																					
	Ø (2)	50												65						75																			
	2	Ø8 x 1000																																					

(1) = 10 x (- 1). « »

(2) 10 .

(3) 250M = 6314 + 2 x 7314 / 225S-M = 2 x 7310

		"A"																					
		32/125A	32/160A	32/200A	40/125A	40/160A	40/200A	50/125A	50/160A	32/250A	40/250A	50/200A	50/250A	65/125A	65/160A	65/200A	80/160A	40/315A	50/315A	65/250A			
		10	9	12	13	11	20	18	12	12	14	15	24	22	27	10	13	22					
	cm ²	12,6	9,7	13,5	22,5	22,1	32,3	32,8	39	34	35	34	75	69	75	91	24,5	37	55				
		3			10						20				10		20						
		16						22						32									
		35																					
		32																					
		2 x 7307																					
	()	1 x 28/03	1 x 28/03	1 x 28/03	2 x 28/03	1 x 28/03	2 x 28/03	1 x 28/03	2 x 28/03	1 x 28/03	2 x 28/03	2 x 40/02								2 x 7310			
	(1)	40/02																					
	()	« »																					
	P/n	0,005						0,0137						0,0433									
	()																						
	l/	250																					
		320																					
	1	EN 12756 (DIN 249560)																					
	Ø (2)	50																					
	2																						
		Ø8 x 1000																					

(1) = x (- 1). « »
 (2) 10 .

		"A"																	
		65/315A	80/200A	80/250A	80/315A	100/200A	100/250A	100/315A	125/240A	125/250A	150/250A	200/250A	80/400A	100/400A	125/315A	125/400A	150/315A	150/400A	200/330A
		7	20	26	24	40	20	19	28	40	70	9	12	23	22	35	28	50	
	cm ²	34,5	95	103	99	105	136	95	141	139	177	289	95	94	137	227	461		
		7	20			7	20			7	20								
		32						42											
		35						50											
		32						48											
		2 x 7310																	
	()													(3)					
	()	2 x 40/02						2 x 55/02	1 x 55/01	2 x 55/02	2 x 55/01	2 x 55/02							
	(1)	40/2						55/1											
	()	40/2																	
		« »																	
	P/n	0,0433						0,1067											
	()																		
	l/	320						500											
	1	EN 12756 (DIN 249560)																	
	Ø (2)	50						65											
	2																		
		Ø8 x 1000																	

(1) = x (- 1). « »
 (2) 10 .
 (3) 250M = 6314 + 2 x 7314 / 225S-M = 2 x 7310

11.

102	
135	
143	
160	
161	
211	
212	
230	
301	
320	
341	
360	
382	
400	
412	
420	
422	
433	
452	
458	
461	
471	
484	
502	
505	
520	
523	
542	
545	
554	
636	
703	
711	
712	
800	
840	
844	()
867	
890	
900	
901	
902	
903	
904	
914	
920	
922	
923	
940	

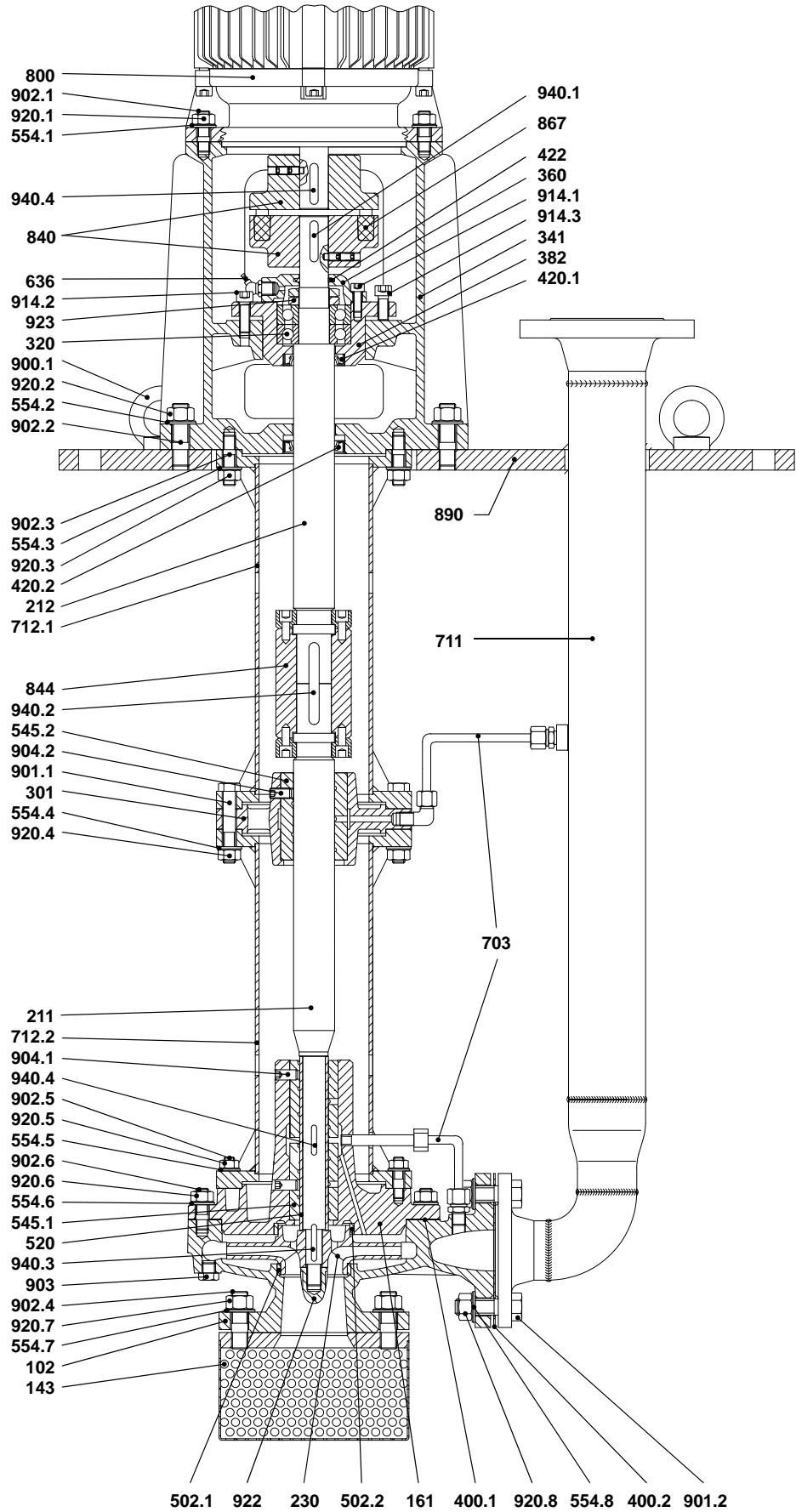

(C)

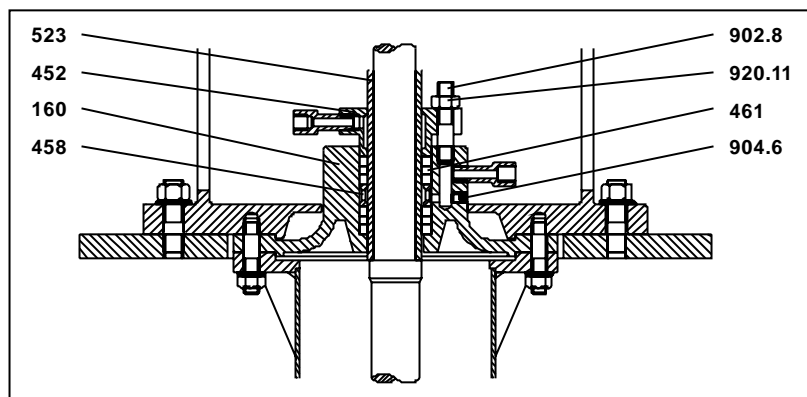
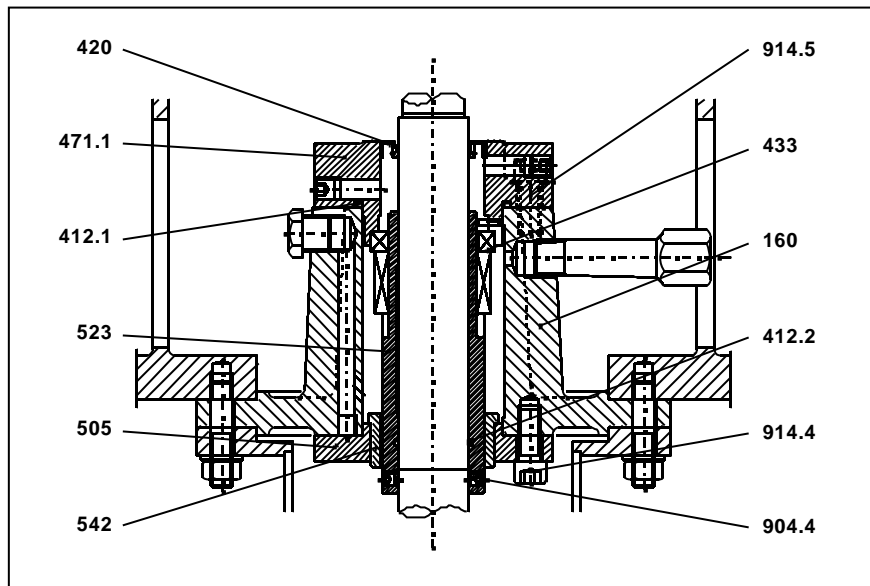
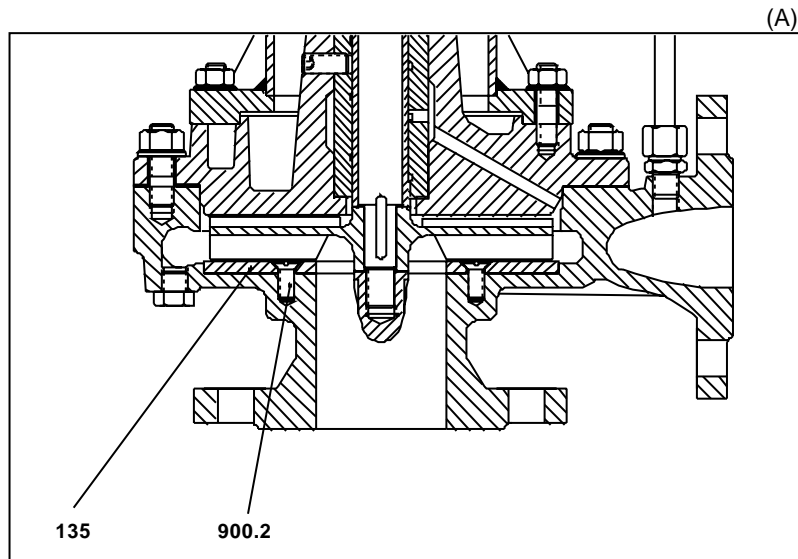

12.

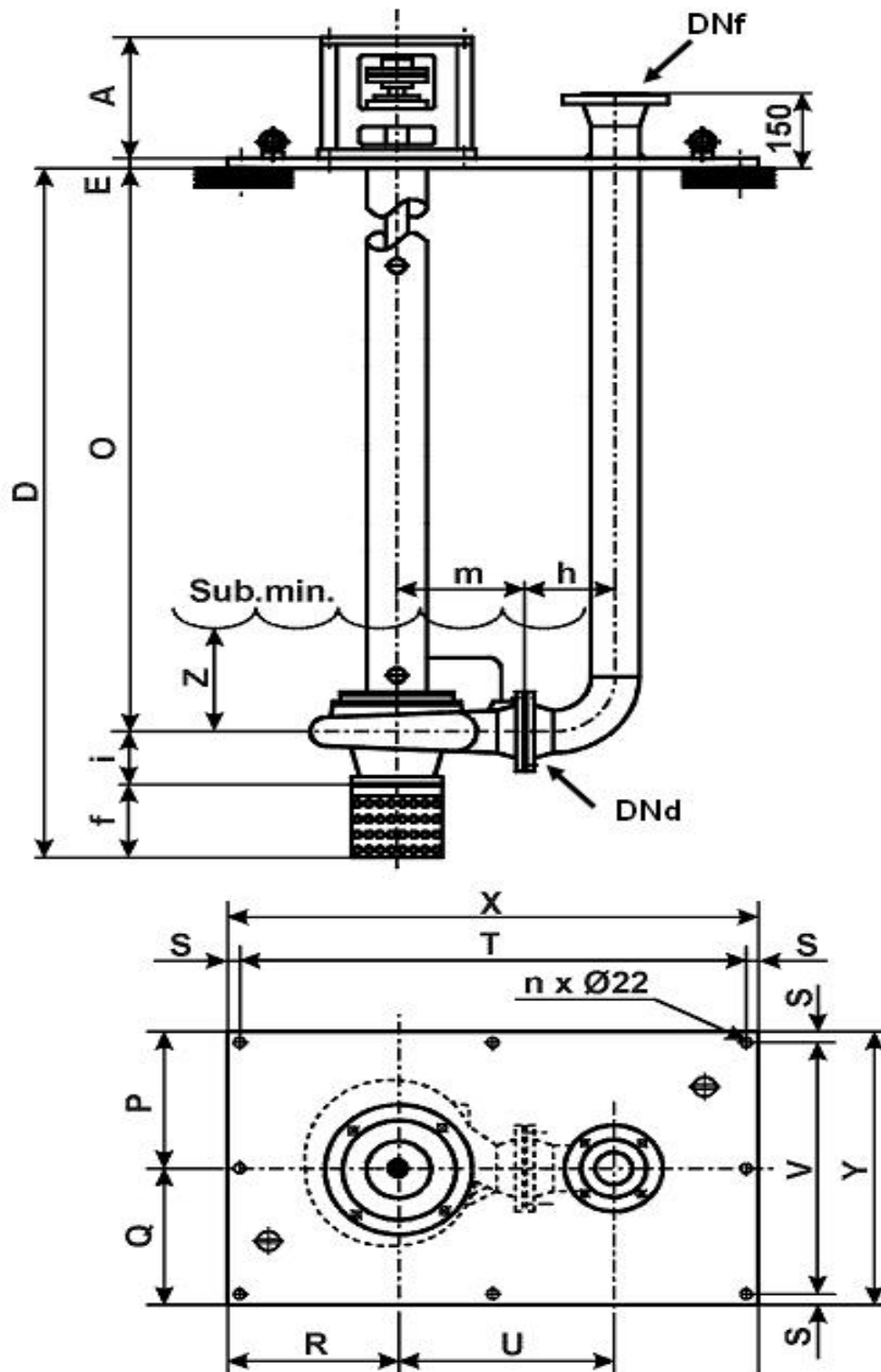

	f		i		n	P	Q	R	S	T	U	V	X	Y	Z
32/125	100	90	80	140	8	200	200	200	30	540	230	340	600	400	120
32/160	100	90	80	160	8	225	225	225	30	590	250	390	650	450	120
32/200	100	90	80	180	8	230	230	230	30	610	270	400	650	460	200
32/250	100	90	100	225	8	240	240	250	30	680	315	420	740	480	200
40/125	100	102	80	140	8	190	190	190	30	520	242	320	580	380	120
40/160	100	102	80	160	8	230	230	230	30	620	262	400	680	460	120
40/200	100	102	100	180	8	220	220	220	30	590	282	380	650	440	200
40/250	100	102	100	225	8	250	250	250	30	680	327	440	740	500	200
50/125	100	124	100	160	8	200	200	210	30	630	284	340	690	400	220
50/160	100	124	100	180	8	220	220	220	30	660	304	380	720	440	120
50/200	100	124	100	200	8	230	230	220	30	640	324	400	700	460	120
50/250	100	124	100	225	8	240	240	240	30	680	349	420	740	480	220
65/125	100	143	100	180	8	230	230	220	30	680	323	400	740	460	220
65/160	100	143	100	200	8	250	250	250	30	740	343	440	800	500	220
65/200	100	143	100	225	8	260	260	255	30	740	368	460	800	520	120
80/160	100	167	125	225	8	235	235	235	30	740	392	410	800	470	220
40/315	100	102	125	250	8	300	300	300	30	780	352	540	840	600	220
50/315	100	124	125	280	8	300	300	300	30	830	404	540	890	600	220
65/250	100	143	100	250	8	260	260	260	30	770	393	460	830	520	220
65/315	100	143	125	280	8	300	300	310	30	870	423	540	930	600	220
80/200	100	167	125	250	8	250	250	250	30	780	417	440	840	500	220
80/250	100	167	125	280	8	300	300	300	30	870	447	540	930	600	240
80/315	100	167	125	315	8	320	320	320	30	920	482	580	980	640	240
100/190	150	207	125	280	8	300	300	300	30	940	487	540	1000	600	240
100/200	150	207	125	280	8	300	300	300	30	940	487	540	1000	600	220
100/250	150	207	140	280	8	300	300	290	30	920	487	540	980	600	220
100/315	150	207	140	315	8	350	350	350	30	1020	522	640	1080	700	220
125/240	150	248	140	355	8	280	280	280	30	1010	603	500	1070	560	220
125/250	150	248	140	355	8	280	280	280	30	1010	603	500	1070	560	240
150/200	200	286	160	370	8	380	380	350	30	1190	656	700	1250	760	220
80/400	100	167	125	355	8	345	345	345	30	980	522	630	1040	690	220
100/400	150	207	140	355	8	365	365	365	30	1080	562	670	1140	730	240
125/315	150	248	140	355	8	350	350	355	30	1110	603	640	1170	700	240
125/400	150	248	140	400	8	350	350	380	30	1210	648	640	1270	700	240
150/315	200	286	160	400	8	350	350	330	30	1190	686	640	1250	700	240
150/400	200	286	160	450	8	400	400	400	30	1280	736	740	1340	800	240
150/240	200	286	160	400	8	360	360	344	30	1200	686	660	1260	720	240
150/250	200	286	160	400	8	360	360	344	30	1200	686	660	1260	720	240
150/500	200	286	200	500	8	460	460	460	30	1460	786	860	1520	920	440
200/240	200	370	200	400	8	400	400	430	30	1440	770	740	1500	800	260
200/250	200	370	200	400	8	400	400	430	30	1440	770	740	1500	800	260
200/330	250	370	200	450	12	420	420	400	30	1420	820	780	1480	840	260
200/400	250	370	200	470	12	470	420	450	30	1480	840	830	1540	890	300
250/300	250	452	230	470	12	400	400	400	30	1540	922	740	1600	800	400
250/400	300	452	250	500	12	500	500	470	40	1620	952	920	1700	1000	300
300/300	300	528	250	500	12	500	500	500	30	1800	1028	940	1860	1000	400
300/350	350	528	250	540	12	500	500	500	30	1840	1068	940	1900	1000	500

A, B, C E . « ».
O D . « ».

DNd	DNf [/"] (1)					
	32	32	1 1/4"	40	1 1/2"	50
40	40	1 1/2"	50	2"	65	2 1/2"
50	50	2"	65	2 1/2"	80	3"
65	65	2 1/2"	80	3"	100	4"
80	80	3"	100	4"	125	5"
100	100	4"	125	5"	150	6"
125	125	5"	150	6"	200	8"
150	150	6"	200	8"	250	10"
200	200	8"	250	10"	300	12"
250	250	10"	300	12"	350	14"
300	300	12"	350	14"	400	16"

(1) EN 1092 / DIN PN10
ANSI B16.5 150#

		"O"											
		32/125	32/160	32/200	32/250	40/125	40/160	40/200	40/250	40/315	50/125	50/160	50/200
1		440	440	440	440	440	440	440	440	455	440	440	440
		640	640	640	640	640	640	640	640	655	640	640	640
		840	840	840	840	840	840	840	840	855	840	840	840
		1040	1040	1040	1040	1040	1040	1040	1040	1055	1040	1040	1040
		1290	1290	1290	1290	1290	1290	1290	1290	1305	1290	1290	1290
		1540	1540	1540	1540	1540	1540	1540	1540	1555	1540	1540	1540
		1790	1790	1790	1790	1790	1790	1790	1790	1805	1790	1790	1790
2		1960	1960	1960	1960	1960	1960	1960	1960	1980	1960	1960	1960
		2060	2060	2060	2060	2060	2060	2060	2060	2080	2060	2060	2060
		2210	2210	2210	2210	2210	2210	2210	2210	2230	2210	2210	2210
		2360	2360	2360	2360	2360	2360	2360	2360	2380	2360	2360	2360
		2560	2560	2560	2560	2560	2560	2560	2560	2580	2560	2560	2560
		2810	2810	2810	2810	2810	2810	2810	2810	2830	2810	2810	2810
		3060	3060	3060	3060	3060	3060	3060	3060	3080	3060	3060	3060
		3310	3310	3310	3310	3310	3310	3310	3310	3330	3310	3310	3310
3		3560	3560	3560	3560	3560	3560	3560	3560	3580	3560	3560	3560
		3830	3830	3830	3830	3830	3830	3830	3830	3855	3830	3830	3830
		4080	4080	4080	4080	4080	4080	4080	4080	4105	4080	4080	4080
		4580	4580	4580	4580	4580	4580	4580	4580	4605	4580	4580	4580
		4830	4830	4830	4830	4830	4830	4830	4830	4855	4830	4830	4830
		5080	5080	5080	5080	5080	5080	5080	5080	5105	5080	5080	5080
	5330	5330	5330	5330	5330	5330	5330	5330	5355	5330	5330	5330	
(1)									(2)	(1)			

		50/250	50/315	65/125	65/160	65/200	65/250	65/315	80/160	80/200	80/250	80/315	80/400
1		440	455	440	440	440	455	455	440	455	455	455	468
		640	655	640	640	640	655	655	640	655	655	655	668
		840	855	840	840	840	855	855	840	855	855	855	868
		1040	1055	1040	1040	1040	1055	1055	1040	1055	1055	1055	1068
		1290	1305	1290	1290	1290	1305	1305	1290	1305	1305	1305	1318
		1540	1555	1540	1540	1540	1555	1555	1540	1555	1555	1555	1568
		1790	1805	1790	1790	1790	1805	1805	1790	1805	1805	1805	1818
2		1960	1980	1960	1960	1960	1980	1980	1960	1980	1980	1980	1993
		2060	2080	2060	2060	2060	2080	2080	2060	2080	2080	2080	2093
		2210	2230	2210	2210	2210	2230	2230	2210	2230	2230	2230	2243
		2360	2380	2360	2360	2360	2380	2380	2360	2380	2380	2380	2393
		2560	2580	2560	2560	2560	2580	2580	2560	2580	2580	2580	2593
		2810	2830	2810	2810	2810	2830	2830	2810	2830	2830	2830	2843
		3060	3080	3060	3060	3060	3080	3080	3060	3080	3080	3080	3093
		3310	3330	3310	3310	3310	3330	3330	3310	3330	3330	3330	3343
3		3560	3580	3560	3560	3560	3580	3580	3560	3580	3580	3580	3593
		3830	3855	3830	3830	3830	3855	3855	3830	3855	3855	3855	3868
		4080	4105	4080	4080	4080	4105	4105	4080	4105	4105	4105	4118
		4580	4605	4580	4580	4580	4605	4605	4580	4605	4605	4605	4618
		4830	4855	4830	4830	4830	4855	4855	4830	4855	4855	4855	4868
		5080	5105	5080	5080	5080	5105	5105	5080	5105	5105	5105	5118
	5330	5355	5330	5330	5330	5355	5355	5330	5355	5355	5355	5368	
(1)		(2)	(1)				(2)		(1)	(2)			

(1)
(2)
15 /

250 M

20

15
225S/M

"Ö"												
	100/190	100/200	100/250	100/315	100/400	125/240	125/250	125/315	125/400	150/200	150/240	150/250
1	455	455	455	455	468	455	455	463	463	455	460	460
	655	655	655	655	668	655	655	663	663	655	660	660
	855	855	855	855	868	855	855	863	863	855	860	860
	1055	1055	1055	1055	1068	1055	1055	1063	1063	1055	1060	1060
	1305	1305	1305	1305	1318	1305	1305	1313	1313	1305	1310	1310
	1555	1555	1555	1555	1568	1555	1555	1563	1563	1555	1560	1560
	1805	1805	1805	1805	1818	1805	1805	1813	1813	1805	1810	1810
2	1980	1980	1980	1980	1993	1980	1980	1988	1988	1980	1985	1985
	2080	2080	2080	2080	2093	2080	2080	2088	2088	2080	2085	2085
	2230	2230	2230	2230	2243	2230	2230	2238	2238	2230	2235	2235
	2380	2380	2380	2380	2393	2380	2380	2388	2388	2380	2385	2385
	2580	2580	2580	2580	2593	2580	2580	2588	2588	2580	2585	2585
	2830	2830	2830	2830	2843	2830	2830	2838	2838	2830	2835	2835
	3080	3080	3080	3080	3093	3080	3080	3088	3088	3080	3085	3085
	3330	3330	3330	3330	3343	3330	3330	3338	3338	3330	3335	3335
	3580	3580	3580	3580	3593	3580	3580	3588	3588	3580	3585	3585
3	3855	3855	3855	3855	3868	3855	3855	3863	3863	3855	3860	3860
	4105	4105	4105	4105	4118	4105	4105	4113	4113	4105	4110	4110
	4605	4605	4605	4605	4618	4605	4605	4613	4613	4605	4610	4610
	4855	4855	4855	4855	4868	4855	4855	4863	4863	4855	4860	4860
	5105	5105	5105	5105	5118	5105	5105	5113	5113	5105	5110	5110
	5355	5355	5355	5355	5368	5355	5355	5363	5363	5355	5360	5360
(2)												

	150/315	150/400	150/500	200/240	200/250	200/330	200/400	250/300	250/400	300/300	300/350
1	463	463	465	470	470	485	474	485	485	510	510
	663	663	665	670	670	685	674	685	685	710	710
	863	863	865	870	870	885	874	885	885	910	910
	1063	1063	1065	1070	1070	1085	1074	1085	1085	1110	1110
	1313	1313	1315	1320	1320	1335	1324	1335	1335	1360	1360
	1563	1563	1565	1570	1570	1585	1574	1585	1585	1610	1610
	1813	1813	1815	1820	1820	1835	1824	1835	1835	1860	1860
2	1988	1988	1990	1995	1995	2010	1999	2010	2010	2035	2035
	2088	2088	2090	2095	2095	2110	2099	2110	2110	2135	2135
	2238	2238	2240	2245	2245	2260	2249	2260	2260	2285	2285
	2388	2388	2390	2395	2395	2410	2399	2410	2410	2435	2435
	2588	2588	2590	2595	2595	2610	2599	2610	2610	2635	2635
	2838	2838	2840	2845	2845	2860	2849	2860	2860	2885	2885
	3088	3088	3090	3095	3095	3110	3099	3110	3110	3135	3135
	3338	3338	3340	3345	3345	3360	3349	3360	3360	3385	3385
	3588	3588	3590	3595	3595	3610	3599	3610	3610	3635	3635
3	3863	3863	3865	3870	3870	3885	3874	3885	3885	3910	3910
	4113	4113	4115	4120	4120	4135	4124	4135	4135	4160	4160
	4613	4613	4615	4620	4620	4635	4624	4635	4635	4660	4660
	4863	4863	4865	4870	4870	4885	4874	4885	4885	4910	4910
	5113	5113	5115	5120	5120	5135	5124	5135	5135	5160	5160
	5363	5363	5365	5370	5370	5385	5374	5385	5385	5410	5410
	(2)	(3)	(2)	(3)	(2)	(3)	(2)	(3)			

(2)
(3)

225S/M
20

15

		"D" ()											
		32/125	32/160	32/200	32/250	40/125	40/160	40/200	40/250	40/315	50/125	50/160	50/200
1		620	620	620	640	620	620	640	640	680	640	640	640
		820	820	820	840	820	820	840	840	880	840	840	840
		1020	1020	1020	1040	1020	1020	1040	1040	1080	1040	1040	1040
		1220	1220	1220	1240	1220	1220	1240	1240	1280	1240	1240	1240
		1470	1470	1470	1490	1470	1470	1490	1490	1530	1490	1490	1490
		1720	1720	1720	1740	1720	1720	1740	1740	1780	1740	1740	1740
		1970	1970	1970	1990	1970	1970	1990	1990	2030	1990	1990	1990
2		2140	2140	2140	2160	2140	2140	2160	2160	2205	2160	2160	2160
		2240	2240	2240	2260	2240	2240	2260	2260	2305	2260	2260	2260
		2390	2390	2390	2410	2390	2390	2410	2410	2455	2410	2410	2410
		2540	2540	2540	2560	2540	2540	2560	2560	2605	2560	2560	2560
		2740	2740	2740	2760	2740	2740	2760	2760	2805	2760	2760	2760
		2990	2990	2990	3010	2990	2990	3010	3010	3055	3010	3010	3010
		3240	3240	3240	3260	3240	3240	3260	3260	3305	3260	3260	3260
		3490	3490	3490	3510	3490	3490	3510	3510	3555	3510	3510	3510
3		3740	3740	3740	3760	3740	3740	3760	3760	3805	3760	3760	3760
		4010	4010	4010	4030	4010	4010	4030	4030	4080	4030	4030	4030
		4260	4260	4260	4280	4260	4260	4280	4280	4330	4280	4280	4280
		4760	4760	4760	4780	4760	4760	4780	4780	4830	4780	4780	4780
		5010	5010	5010	5030	5010	5010	5030	5030	5080	5030	5030	5030
		5260	5260	5260	5280	5260	5260	5280	5280	5330	5280	5280	5280
										(1)	(2)	(1)	

		50/250	50/315	65/125	65/160	65/200	65/250	65/315	80/160	80/200	80/250	80/315	80/400
1		640	680	640	640	640	655	680	665	680	680	680	693
		840	880	840	840	840	855	880	865	880	880	880	893
		1040	1080	1040	1040	1040	1055	1080	1065	1080	1080	1080	1093
		1240	1280	1240	1240	1240	1255	1280	1265	1280	1280	1280	1293
		1490	1530	1490	1490	1490	1505	1530	1515	1530	1530	1530	1543
		1740	1780	1740	1740	1740	1755	1780	1765	1780	1780	1780	1793
		1990	2030	1990	1990	1990	2005	2030	2015	2030	2030	2030	2043
2		2160	2205	2160	2160	2160	2180	2205	2185	2205	2205	2205	2218
		2260	2305	2260	2260	2260	2280	2305	2285	2305	2305	2305	2318
		2410	2455	2410	2410	2410	2430	2455	2435	2455	2455	2455	2468
		2560	2605	2560	2560	2560	2580	2605	2585	2605	2605	2605	2618
		2760	2805	2760	2760	2760	2780	2805	2785	2805	2805	2805	2818
		3010	3055	3010	3010	3010	3030	3055	3035	3055	3055	3055	3068
		3260	3305	3260	3260	3260	3280	3305	3285	3305	3305	3305	3318
		3510	3555	3510	3510	3510	3530	3555	3535	3555	3555	3555	3568
3		3760	3805	3760	3760	3760	3780	3805	3785	3805	3805	3805	3818
		4030	4080	4030	4030	4030	4055	4080	4055	4080	4080	4080	4093
		4280	4330	4280	4280	4280	4305	4330	4305	4330	4330	4330	4343
		4780	4830	4780	4780	4780	4805	4830	4805	4830	4830	4830	4843
		5030	5080	5030	5030	5030	5055	5080	5055	5080	5080	5080	5093
		5280	5330	5280	5280	5280	5305	5330	5305	5330	5330	5330	5343
		(1)	(2)	(1)			(2)		(1)	(2)			

(1)
(2)

15 /

250 M

20

15
225S/M

		"D" ()											
		100/190	100/200	100/250	100/315	100/400	125/240	125/250	125/315	125/400	150/200	150/240	150/250
1	,	730	730	745	745	758	745	745	753	753	815	820	820
		930	930	945	945	958	945	945	953	953	1015	1020	1020
		1130	1130	1145	1145	1158	1145	1145	1153	1153	1215	1220	1220
		1330	1330	1345	1345	1358	1345	1345	1353	1353	1415	1420	1420
		1580	1580	1595	1595	1608	1595	1595	1603	1603	1665	1670	1670
		1830	1830	1845	1845	1858	1845	1845	1853	1853	1915	1920	1920
		2080	2080	2095	2095	2108	2095	2095	2103	2103	2165	2170	2170
2	,	2255	2255	2270	2270	2283	2270	2270	2278	2278	2340	2345	2345
		2355	2355	2370	2370	2383	2370	2370	2378	2378	2440	2445	2445
		2505	2505	2520	2520	2533	2520	2520	2528	2528	2590	2595	2595
		2655	2655	2670	2670	2683	2670	2670	2678	2678	2740	2745	2745
		2855	2855	2870	2870	2883	2870	2870	2878	2878	2940	2945	2945
		3105	3105	3120	3120	3133	3120	3120	3128	3128	3190	3195	3195
		3355	3355	3370	3370	3383	3370	3370	3378	3378	3440	3445	3445
		3605	3605	3620	3620	3633	3620	3620	3628	3628	3690	3695	3695
3	,	3855	3855	3870	3870	3883	3870	3870	3878	3878	3940	3945	3945
		4130	4130	4145	4145	4158	4145	4145	4153	4153	4215	4220	4220
		4380	4380	4395	4395	4408	4395	4395	4403	4403	4465	4470	4470
		4880	4880	4895	4895	4908	4895	4895	4903	4903	4965	4970	4970
		5130	5130	5145	5145	5158	5145	5145	5153	5153	5215	5220	5220
		5380	5380	5395	5395	5408	5395	5395	5403	5403	5465	5470	5470
		(2)											

		150/315	150/400	150/500	200/240	200/250	200/330	200/400	250/300	250/400	300/300	300/350
1	,	823	823	865	870	870	935	924	965	1035	1060	1110
		1023	1023	1065	1070	1070	1135	1124	1165	1235	1260	1310
		1223	1223	1265	1270	1270	1335	1324	1365	1435	1460	1510
		1423	1423	1465	1470	1470	1535	1524	1565	1635	1660	1710
		1673	1673	1715	1720	1720	1785	1774	1815	1885	1910	1960
		1923	1923	1965	1970	1970	2035	2024	2065	2135	2160	2210
		2173	2173	2215	2220	2220	2285	2274	2315	2385	2410	2460
2	,	2348	2348	2390	2395	2395	2460	2449	2490	2560	2585	2635
		2448	2448	2490	2495	2495	2560	2549	2590	2660	2685	2735
		2598	2598	2640	2645	2645	2710	2699	2740	2810	2835	2885
		2748	2748	2790	2795	2795	2860	2849	2890	2960	2985	3035
		2948	2948	2990	2995	2995	3060	3049	3090	3160	3185	3235
		3198	3198	3240	3245	3245	3310	3299	3340	3410	3435	3485
		3448	3448	3490	3495	3495	3560	3549	3590	3660	3685	3735
		3698	3698	3740	3745	3745	3810	3799	3840	3910	3935	3985
3	,	3948	3948	3990	3995	3995	4060	4049	4090	4160	4185	4235
		4223	4223	4265	4270	4270	4335	4324	4365	4435	4460	4510
		4473	4473	4515	4520	4520	4585	4574	4615	4685	4710	4760
		4973	4973	5015	5020	5020	5085	5074	5115	5185	5210	5260
		5223	5223	5265	5270	5270	5335	5324	5365	5435	5460	5510
		5473	5473	5515	5520	5520	5585	5574	5615	5685	5710	5760
		(2)	(3)	(2)			(3)	(2)	(3)			

(2) 225S/M

15 /

250 M

20

20

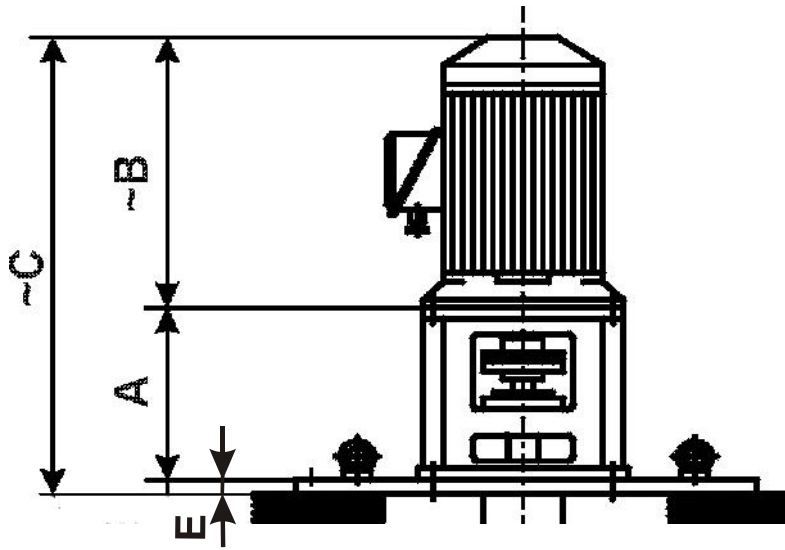

		A	B	E	C			
32/125 32/160 32/200 32/250 40/125 40/160 40/200 40/250 50/125 50/160 50/200 50/250 65/125 65/160 65/200 65/250 80/160	225 (4-)	460	666	20	1146			
	225 (2-)	430			(1)	1116	(1)	
	200					660	1110	
	180	355			602	977		
	160				478	853		
	132		325		373	718		
	112	305	(2)		333	658	(2)	
	100				312	637		
	90		335		281	636		
	80	325	234		579			
	40/315 50/315 65/250 65/315 80/200 80/250 80/315 100/190 100/200 100/250 100/315 125/240 125/250 150/200 150/240 150/250 200/240 200/250	280	600		(3)	820	1440	(3)
		250				747	1367	
		225 (4-)	460			666	1146	
		225 (2-)	430			666	1116	
		200				660	1110	
180				602	1052			
160		400	(2)	478	928	(2)		
132				373	793			
112				333	753			
100				312	732			

(1)

55

(2)

60

(3)

80

		A	B	E	C			
80/400 100/400	280	600	(3)	20	820	1440	(3)	
	250				747	1367		
	225 (4-)	460			666	1146		
	225 (2-)	430	(2)		660	1110	(2)	
	200				602	1052		
	180				478	928		
	160	430			373	793		
	132	400						
	125/315 125/400 150/315 150/400 200/330 250/300	280	600		(3)	820	1445	(3)
		250				747	772	
225 (4-)		460		666	1151			
225 (2-)		430	(2)	660	685	(2)		
200				602	627			
180				478	503			
160	400		373	798				
132								
150/500 200/400 250/400 300/300 300/350	315	630		932	1592	(3)		
	280	600	(3)	820	1450			
	250			747	1377			
	225 (4-)			666	1296			
	225 (2-)	1296						
	200	660	1290					

13.

40
: 70 °C. , RAL 5010.

14.

		()						
		1-2	3	4	5	6-7	8-9	10
---	()	2	3	4	5	6	7	90%
433		2	3	4	5	6	7	90%
461		2	3	4	5	6	7	90%
135		1	1	2	2	2	3	30%
320	()	1	1	2	2	2	3	30%
420	()	1	1	2	2	2	3	30%
422	()	1	1	2	2	2	3	30%
458		1	1	2	2	2	3	30%
502	()	1	1	2	2	2	3	30%
520		1	1	2	2	2	3	30%
523		1	1	2	2	2	3	30%
545	()	1	1	2	2	3	4	50%
867	()	1	1	2	2	2	3	30%
922		1	1	2	2	2	3	30%
940	()	1	1	2	2	2	3	30%
211-213	()	1	1	2	2	2	3	30%
230		1	1	2	2	2	3	30%
840	()	1	1	2	2	2	3	30%



KSB ITUR Spain, S.A.

Camino de Urteta s/n · 20800 Zarautz (Spain)
Tel. +34 943 899 899 www.ksb.es